

LAND USE:
 USE: PUBLIC SCHOOL OTHER THAN OPEN ENROLLMENT CHARTER SCHOOL

LOT CALCULATIONS:
 TOTAL LAND AREA = 770,659 SF OR 17.69 AC.
 BUILDING AREA TOTAL = 130,851 SQ. FT.
 BUILDING (2 STORY BLDG.)
 MAX. BUILDING HEIGHT = 35'-0"
 TOTAL PROPOSED CLASSROOMS = 60

FLOOR TO AREA RATIO
 BUILDING AREA / LOT AREA
 130,851 SQ FT / 770,659 SQ FT = 16.9% LOT COVERAGE

PARKING:
 PROVIDED - 60 CLASSROOMS @ 3.0 = 180 PARKING SPACES

LANDSCAPE:
 ALL NEW LARGE TREE'S ARE PER ARTICLE X

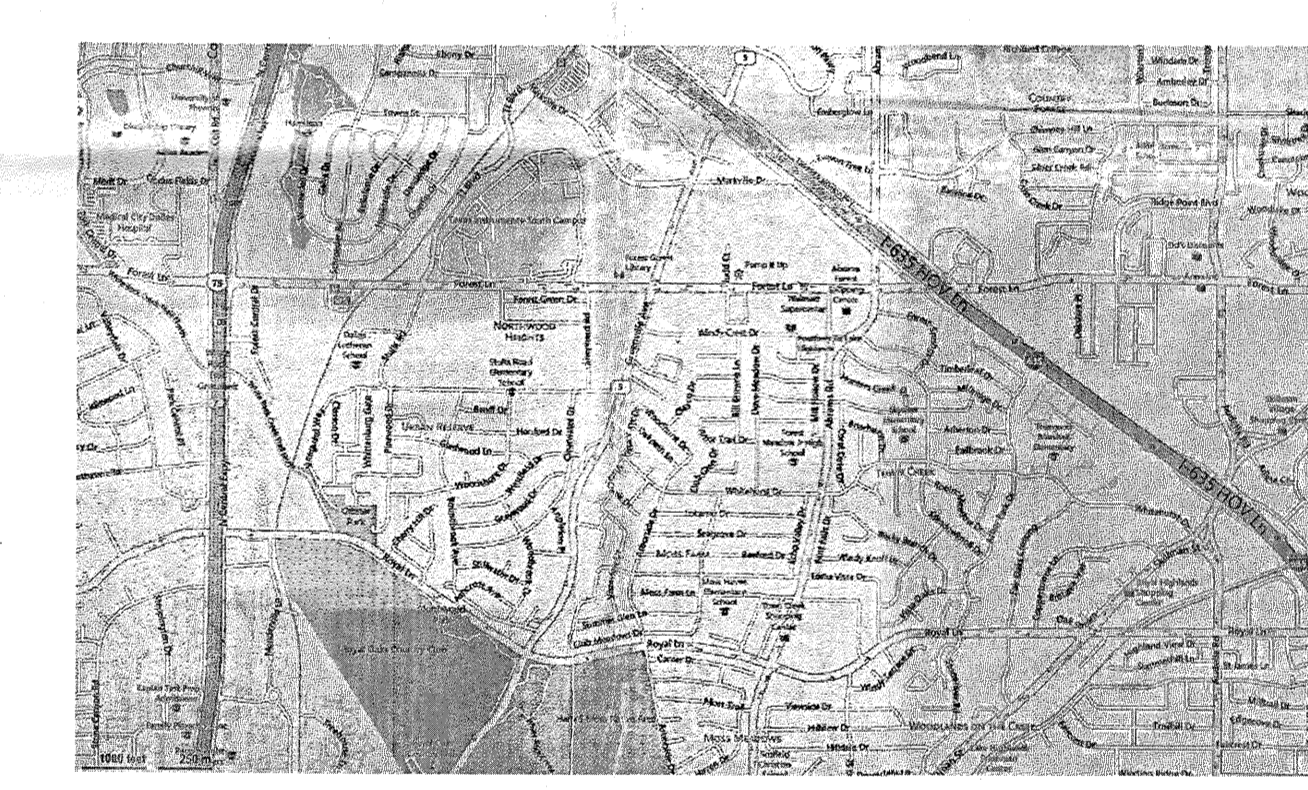

VICINITY MAP
 NTS
 MAPSCO 3G

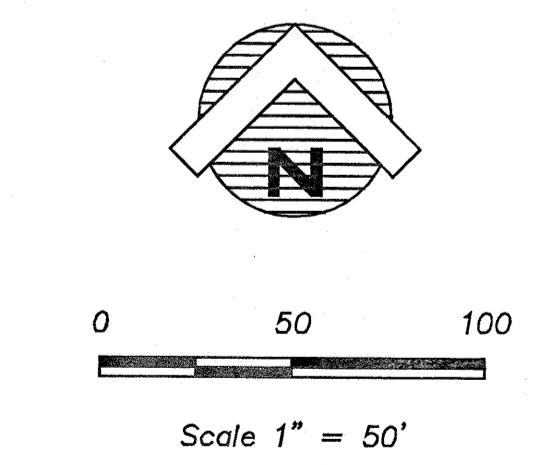

ARCHITECT
 CORGAN ASSOCIATES, INC.
 401 HOUSTON STREET
 DALLAS, TEXAS 75202
 (214) 748-2000

OWNER
 RICHARDSON ISD
 400 S. GREENVILLE AVE.
 RICHARDSON, TEXAS 75081
 469-593-0000

131871
 29181

APPROVED BY
 CITY COUNCIL
 OCT 2 3 2013
 Lisa C. Lewis
 City Secretary

GLENN ENGINEERING
 T.B.P.E. FIRM REGISTRATION NO. F - 303
 PHONE 972-717-5151 FAX 972-717-2178
 105 DECKER COURT - SUITE 910 IRVING, TEXAS 75062

CORGAN ASSOCIATES, INC.
 401 North Houston Street
 Dallas, Texas 75202
 Tel 214 748 2000
 Fax 214 653 8291

01	60% REVIEW SET
02	07/03/2013
02	75% REVIEW SET
03	07/25/2013
04	95% REVIEW SET
05	08/23/2013
06	100% ISSUE FOR CONSTRUCTION
05	09/05/13
07	
08	
Δ	REVISIONS

Forest Meadow Junior High School

9373 Whitehurst Dr.
 DALLAS, TEXAS, 75243

FOREST MEADOW JH DEVELOPMENT / LANDSCAPE PLAN Z123 - 316 (RB)

Planned Development
 No. 897
 Exhibit 897A

Approved
 City Plan Commission
 September 26, 2013